



Heating and Air Conditioning

TECHNICAL GUIDE (R-407C)

SINGLE PACKAGE

GAS/ELECTRIC UNITS AND

SINGLE PACKAGE AIR CONDITIONERS

DC300 CONSTANT VOLUME

25 NOMINAL TONS

(WORLD 50 HZ)

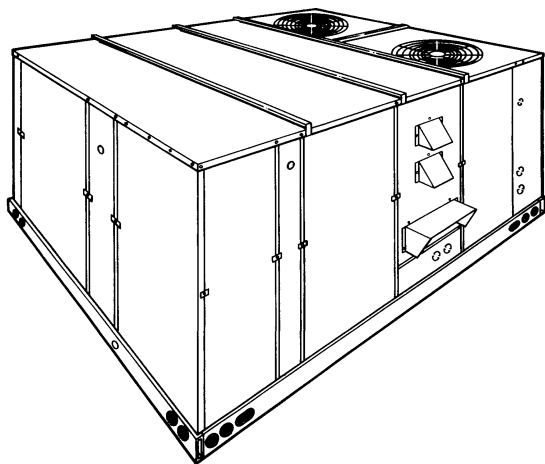

SUNLINE™ 2000



ISO 9001
Certified Quality
Management System

DESCRIPTION

Sunline™ 2000 series convertible package rooftop models have two independent refrigerant circuits for efficient part load operation. Although the units are primarily designed for curb mounting on a roof, they can also be slab-mounted at ground level or set on steel beams above a finished roof.

Cooling only, cooling with gas heat and cooling with electric heat models are available with wide variety of factory-mounted options and field-installed accessories to make them suitable for almost every application.

All units are self-contained and assembled on full perimeter base rails with holes in the four corners for overhead rigging.

Every unit is completely piped, wired, charged and tested at the factory to simplify the field installation and to provide years of dependable operation. Powder paint cabinets provide an exceptionally durable finish with the 1000 hour salt spray process per ASTM-B117 test standard.

All models (including those with an economizer) are suitable for either bottom or horizontal duct connections. Models with power exhaust are suitable for bottom duct connections only. For bottom duct, remove the sheet metal panels from the supply and return air openings through the base of the unit. For horizontal duct, replace the supply and return air panels on the rear of the unit with a side duct flange accessory.

All models are available with four different outdoor air damper options:

- Single enthalpy economizer with or without power exhaust
- BAS-ready economizer with or without power exhaust
- Motorized outdoor air damper
- Barometric Relief Damper

The enthalpy system contains one sensor that monitors the outdoor air and determines when the air is cool enough and dry enough to provide "free" cooling.

The rainhood is painted to match the basic unit and must be field-assembled before installing.

TABLE OF CONTENTS

DESCRIPTION	1
FACTORY-INSTALLED OPTIONS	4
FIELD-INSTALLED ACCESSORIES	5
PRODUCT NOMENCLATURE	6

LIST OF FIGURES

<u>Fig. #</u>	<u>Pg. #</u>
1 ALTITUDE/TEMPERATURE CONVERSION FACTOR (°C/METER)	11
2 ALTITUDE/TEMPERATURE CONVERSION FACTOR (°F/FEET)	12
3 FIELD WIRING - DC ELECTRIC/ELECTRIC AND GAS/ ELECTRIC UNITS	17
4 UNIT DIMENSIONS - DC COOL & COOL/ELECTRIC HEAT	18
5 UNIT DIMENSIONS - DC GAS HEAT	18
6 REAR VIEW DIMENSIONS	19
7 UNIT CLEARANCES AND RAINHOOD DIMENSIONS (25 TON)	20
8 CENTER OF GRAVITY	20
9 ROOF CURB DIMENSIONS (ALL MODELS)	21
10 ROOF CURB BENEFITS	21
11 UNIT CURB AND APPLICATIONS	21
12 TYPICAL APPLICATION	22
13 TYPICAL ROOF-TOP INSTALLATION (GAS/ELECTRIC UNIT SHOWN)	22

LIST OF TABLES

<u>Tbl. #</u>		<u>Pg. #</u>
1	CAPACITY RATINGS - ELECTRIC HEAT	7
2	CAPACITY RATINGS - GAS HEAT	7
3	SOUND POWER RATING	7
4	DC300 COOLING CAPACITIES - 25 TON (CFM)	8
5	DC300 COOLING CAPACITIES - 25 TON (METRIC) .	9
6	ALTITUDE CORRECTION FACTORS (°C/METER) ..	10
7	ALTITUDE CORRECTION FACTORS (°F/FEET)	10
8	BLOWER PERFORMANCE - DC300 - BOTTOM DUCT CONNECTIONS (COOLING APPLICATIONS)	13
9	STATIC RESISTANCES - EXTERNAL STATIC PRES- SURE DROP	14
10	BLOWER MOTOR AND DRIVE DATA	14
11	PHYSICAL DATA	15
12	ELECTRICAL DATA - COOLING ONLY UNITS AND UNITS WITH GAS HEAT	16
13	ELECTRICAL DATA - UNITS WITH ELECTRIC HEAT	16
14	UTILITIES ENTRY DATA	19
15	MINIMUM CLEARANCES (MM/IN.)	20

DESCRIPTION (Cont'd.)

A fixed outdoor air intake assembly is shipped in the return air compartment of all units ordered without an economizer or motorized outdoor air damper option. The assembly includes a rain hood with a damper that can be set for 10, 15 or 25% outdoor air. With bottom duct connections, the intake damper assembly should be mounted over the opening in the return air panel. With horizontal ductwork, it should be mounted on the return air duct. All supply air blowers are equipped with a belt drive that can be adjusted to meet the exact requirements of the job.

All compressors include internal pressure relief. Every refrigerant circuit includes an expansion valve, a liquid line filter-drier, a discharge line high pressure switch and a suction line with a freeze-stat and low pressure/loss of charge switch, to protect all system components.

Compressors and electric heater elements carry an additional 4-year warranty. Aluminized steel tubular heat exchangers carry an additional 9-year warranty.

- **Simplicity® Controls** - Simplicity® control boards have standardized a number of features previously available only as options or by utilizing additional controls.
- **Low Ambient** - An integrated low-ambient control allows all units to operate in the cooling mode down to 0°F outdoor ambient without additional assistance. Optionally, the control board can be programmed to lockout the compressors when the outdoor air temperature is low or when free cooling is available.

CAUTION

The Simplicity® control board used in this product will effectively operate the cooling system down to 0°F when this product is applied in a comfort cooling application for people. An economizer is typically included in this type of application. When applying this product for process cooling applications (computer rooms, switchgear, etc.), please reference applications bulletin AE-011-07 or call the applications department for Unitary Products @ 1-877-UPG-SERV for guidance. Additional accessories may be needed for stable operation at temperatures below 30°F.

- **Anti-Short Cycle Protection** - To aid compressor life, an anti-short cycle delay is incorporated into the standard controls. Compressor reliability is further ensured by programmable minimum run times. For testing, the anti short cycle delay can be temporarily overridden with the push of a button.
- **Fan Delays** - Fan on and fan off delays are fully programmable. Furthermore, the heating and cooling

fan delay times are independent of one another. All units are programmed with default values based upon their configuration of cooling and heat.

- **Safety Monitoring** - The control board monitors the high and low-pressure switches, the freeze-stats, the gas valve, if applicable, and the temperature limit switch on gas and electric heat units. The unit control board will alarm on ignition failures, compressor lockouts and repeated limit switch trips.
- **Nuisance Trip Protection and Strikes** - To prevent nuisance trouble calls, the control board uses a "three times, you're out" philosophy. The high and low-pressure switches and the freeze-stats must trip three times within two hours before the unit control board will lock out the associated compressor.
- **On Board Diagnostics** - Each alarm will energize a trouble light on the thermostat, if so equipped, and flash an alarm code on the control board LED. Each high and low-pressure switch alarm as well as each freeze-stat alarm has its own flash code. The control board saves the five most recent alarms in memory, and these alarms can be reviewed at any time. Alarms and programmed values are retained through the loss of power.

All gas heat models are built with two heating sections for two equal stages of capacity control. Each section includes a durable heat exchanger with aluminized steel tubes, a redundant gas valve, spark ignition, power venting, an ignition module for 100% shut-off and all of the safety controls required to meet the latest ANSI standards.

The gas supply piping can be routed into the heating compartment through a hole in the base pan of the unit or through a knockout in the piping panel on the front of the unit.

All electric heat models are wired for a single power source and include a bank of nickel chromium elements mounted at the discharge of the supply air blower to provide a high velocity and uniform distribution of air across the heating elements. Every element is fully protected against excessive current and temperature by fuses and two thermal limit switches.

The power supply wiring can be routed into the control box through a threaded pipe connection in the base pan of the unit. It can also be routed knockout in the wiring panel on the front of the unit.

All models are available with factory mounted BAS Control. Options are Novar, Honeywell, Johnson, or CPC.

All internal factory wiring is color coded and numbered for ease in servicing and troubleshooting.

FACTORY-INSTALLED OPTIONS

- **SINGLE INPUT ELECTRONIC ENTHALPY ECONOMIZERS** - Includes a slide-in / plug-in damper assembly with fully modulating spring-return motor actuator capable of introducing up to 100% outdoor air with nominal 1% leakage type dampers.

The enthalpy system contains one sensor that monitors the outdoor air and determines when the air is cool enough and dry enough to provide free cooling.

The rainhood is painted to match the basic unit and must be field-assembled before installing.

- **BAS-READY ECONOMIZER** - Includes a slide-in / plug-in damper assembly with fully modulating spring-return motor actuator with zero to 95-degree rotation capable of introducing up to 100% outdoor air with nominal 1% leakage type dampers.

Actuator requires 2-10 VDC input from an external source, such as a field-installed or factory-installed BAS controller. BAS-ready actuators have an adjustable auxiliary end-switch for optional power exhaust control.

For units with Simplicity® Intelli-Comfort™ control, a factory-installed, dry bulb sensor determines if outdoor air temperature is low enough to provide free-cooling operation. (Field-installed humidity sensors for either outdoor air or outdoor & return air streams are available for single enthalpy and differential enthalpy configurations, respectively).

The rainhood is painted to match the basic unit and must be field-assembled before installing.

- **POWER EXHAUST** - Our economizer options are available with power exhaust. Whenever the outdoor air intake dampers are opened for free cooling, the exhaust fan will be energized to prevent the conditioned space from being over-pressurized during economizer operation. BAS-ready economizer actuators have an adjustable auxiliary end-switch to provide a range of damper positions available to energize power exhaust.

The exhaust fan, motor and controls are installed and wired at the factory. The rain hood must be assembled and installed in the field.

The power exhaust option can only be used on bottom duct configurations.

- **MOTORIZED OUTDOOR AIR INTAKE DAMPER** - Includes a slide-in / plug-in damper assembly with a 2-position, spring return motor actuator which opens to a pre-set position whenever the supply air blower is operating and will drive fully closed when the blower unit shuts down.

The rain hood is painted to match the basic unit and must be field assembled before installing.

- **BAROMETRIC RELIEF DAMPER** - This damper option can be used to relieve internal building air pressure on units with an economizer without power exhaust. This accessory includes a rain hood, a bird screen and a fully assembled damper. With bottom duct connections, the damper should be mounted over the opening in the return air panel. With horizontal ductwork, the accessory should be mounted on the return air duct.
- **PHENOLIC COATED EVAPORATOR AND CONDENSER COILS** - Special coating process that utilizes Technicoat 10-1" processes. Coating is applied by total immersion of the complete coil for maximum protection.
- **ELECTRIC HEATERS** wired for single point power supply. These nickel chromium heater elements are provided with limit and automatic reset capability to prevent operation at excessive temperatures.
- **FILTER OPTIONS** - Standard units are shipped with 2" throw-away filters installed. 2" pleated and 4" pleated filters are offered as a factory installed option.
- **BAS** - See "Additional Options" section in the product nomenclature.
- **SMOKE DETECTORS** - (supply air & return air) The smoke detectors stop operation of the unit by interrupting power to the control board if smoke is detected within the air compartment.

WARNING

Factory installed smoke detectors in the return air, may be subjected to freezing temperatures during "off" times due to outside air infiltration. These smoke detectors have an operational limit of 32°F to 131°F. Smoke detectors installed in areas that could be outside those limitations will have to be moved to prevent having false alarms.

- **COIL GUARD** - Customers can purchase a coil guard kit to protect the condenser coil from damage. This is not a hail guard kit.
- **STAINLESS STEEL HEAT EXCHANGER** - For applications in corrosive environments, this option provides a full stainless steel heat exchanger assembly.
- **PHASE MONITORS** - Designed to prevent unit damage. The phase monitor will shut the unit down in an out-of-phase condition.
- **DIRTY FILTER SWITCH** - This kit includes a differential pressure switch that energizes the fault light on the unit thermostat, indicating that there is an abnormally high pressure drop across the filters. Factory installed option or field installed accessory.
- **HINGED FILTER DOOR/"TOOL FREE" BLOWER AND ACCESS PANELS (not hinged)** - This option allows for easy access and maintenance.

NOTE: Knobs are shipped separately within the unit to prevent shipping damage. These must be field installed for tool free operation.

- **HINGED/"TOOL FREE" BLOWER, BLOWER MOTOR, FILTER AND ELECTRIC ACCESS PANELS** - This option allows for complete hinged and tool free access to the unit's blower, blower motor, filters and electrical panel sections.

FIELD-INSTALLED ACCESSORIES

- **SINGLE INPUT ELECTRONIC ENTHALPY ECONOMIZERS** - Includes a slide-in / plug-in damper assembly with fully modulating spring-return motor actuator capable of introducing up to 100% outdoor air with nominal 1% leakage type dampers.

The enthalpy system contains one sensor that monitors the outdoor air and determines when the air is cool enough and dry enough to provide free cooling.

The rainhood is painted to match the basic unit and must be field-assembled before installing.

Power exhaust is not available as a field installed option.

- **MOTORIZED OUTDOOR AIR INTAKE DAMPER** - Includes a slide-in / plug-in damper assembly with a 2-position, spring return motor actuator which opens to some pre-set position whenever the supply air blower is operating and will drive fully closed when the blower unit shuts down.

The rain hood is painted to match the basic unit and must be field assembled before installing.

Power exhaust is not available as a field installed option.

- **ROOF CURBS** - Fourteen-inch high roof curbs provide a water-tight seal between the unit and the finished roof. These full perimeter curbs meet the requirements of the National Roofing Contractors Association (NRCA) and are shipped knocked-down for field assembly.

They're designed to fit inside the base rails of the unit and include both a wood nailing strip and duct hanger supports.

- **HIGH ALTITUDE NATURAL GAS** - Burner orifices and pilot orifices are provided for proper furnace operation at altitudes up to 6,000 feet.
- **PROPANE** - Burner orifices, pilot orifices and gas valve parts are provided to convert a natural gas furnace to propane.
- **HIGH ALTITUDE PROPANE** - Burner orifices and pilot orifices are provided for proper furnace operation at altitudes up to 6,000 feet. This accessory supplements the basic propane conversion kit.
- **SIDE DUCT FLANGES** - One-inch flanges replace the supply and return air panels on the rear of the unit to accommodate horizontal duct connections. These

flanges can also be used individually for bottom supply/horizontal return or horizontal supply/bottom return. They cannot be used on units with power exhaust.

- **BAROMETRIC RELIEF DAMPER** - This damper accessory can be used to relieve internal building air pressure on units with an economizer without power exhaust. This accessory includes a rain hood, a bird screen and a fully assembled damper. With bottom duct connections, the damper should be mounted over the opening in the return air panel. With horizontal ductwork, the accessory should be mounted on the return air duct.
- **ENTHALPY ACCESSORY CONTROL KIT** - This kit contains the required components to convert a single enthalpy economizer to dual enthalpy.
- **BURGLAR BARS** - Mount in the supply and return openings to prevent entry into the duct work.
- **FLUE EXHAUST EXTENSION KIT** - In locations with wind or weather conditions which may interfere with proper exhausting of furnace combustion products, this kit can be installed to prevent the flue exhaust from entering nearby fresh air intakes.
- **WOOD SKID** - Allows unit to be handled with 90" forks.
- **CO₂ SENSOR** - Senses CO₂ levels and automatically overrides the economizer when levels rise above the present limits.
- **COIL GUARD** - Customers can purchase a coil guard kit to protect the condenser coil from damage. This is not a hail guard kit. Model 1CG0415.
- **PHASE MONITORS** - Designed to prevent unit damage. The phase monitor will shut the unit down in an out-of-phase condition.

PRODUCT NOMENCLATURE

25 Ton Sunline 2000® Model Number Nomenclature

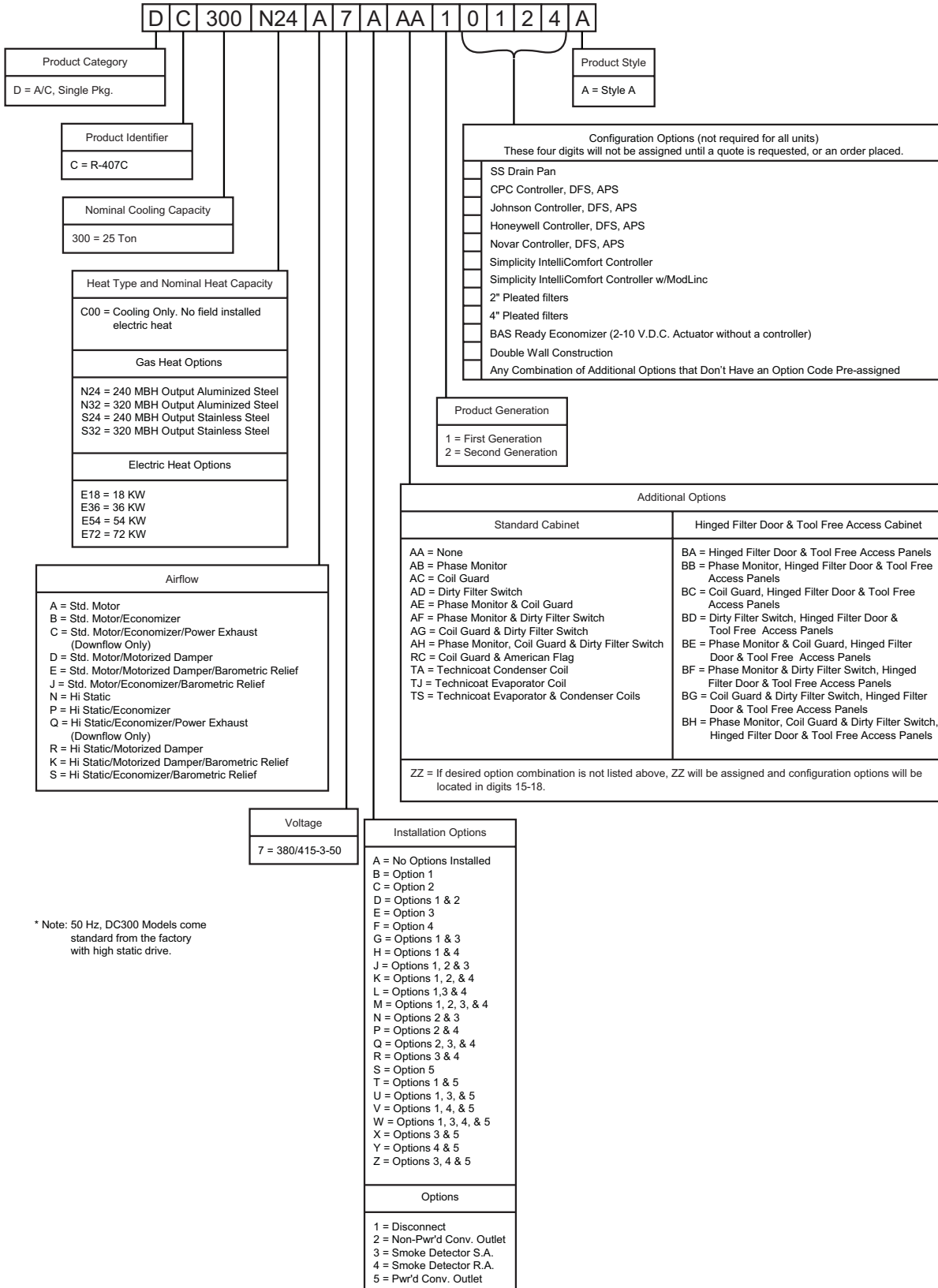

TABLE 1: CAPACITY RATINGS - ELECTRIC HEAT

Model	Electric Heat ¹ Nominal Capacity kW
DC300	18, 36, 54, 72

1. Heaters available as factory - installed options or field - installed accessories - all with single point power supply.

TABLE 2: CAPACITY RATINGS - GAS HEAT

Model	Gas Heat Capacity				
	Input Mbh/kW	Output Mbh/kW	Gas Rate cfh/ m ³ /h	Temp. Rise (°F / °C) At Full Input	
				Min.	Max.
DC300N24	300 / 85.2	240 / 70.3	279 / 7.9	20 / 11	50 / 28
DC300N32	350 / 102.6	280 / 82	326 / 9.2	30 / 17	60 / 33

TABLE 3: SOUND POWER RATING¹

UNIT SIZE	CFM	ESP	BLOWER		SOUND POWER (db 10 ⁻¹² Watts)									
					Octave Band Centerline Frequency (Hz)								SWL dB(A)	dB(A) @ 10Ft. ²
					IWG	RPM	BHP	63	125	250	500	1,000		
DC300	10,000	1.30	1160	12.5	108	108	98	91	93	86	81	76	98	65

1. These values have been accessed using a model of sound propagation from a point source into the hemispheric/free field. The dBA values provided are to be used for reference only. Calculation of dBA values cover matters of system design and the fan manufacture has no way of knowing the details of each system. This constitutes and expectation to any specification or guarantee requiring a dBA value or sound data in any other form than sound power level ratings.
2. At a distance of 10 feet from the blower.

TABLE 4: DC300 COOLING CAPACITIES - 25 TON (CFM)

Air on Evaporator Coil		Temperature of Air on Condenser Coil															
CFM	WB (°F)	Total Cap. ¹ (MBh)	Total Input ² (kW)	Sensible Capacity (MBh) Return Dry Bulb (°F)						Total Cap. ¹ (kW)	Total Input ² (MBh)	Sensible Capacity (MBh) Return Dry Bulb (°F)					
				90	85	80	75	70	65			90	85	80	75	70	65
		75°F							85°F								
7500	77	330.6	22.6	157.9	128.7	99.6	-	-	-	317.1	24.7	153.2	124.4	95.7	-	-	-
	72	313.1	21.8	207.4	178.2	149.0	119.9	-	-	298.9	24.0	201.1	172.3	143.5	114.8	-	-
	67	295.7	20.9	256.8	227.7	198.5	169.3	140.1	-	280.7	23.3	249.0	220.2	191.4	162.7	133.9	-
	62	262.5	20.7	262.5	262.5	237.7	208.5	179.3	150.2	253.9	22.9	253.9	253.9	231.6	202.8	174.1	145.3
	57	261.5	20.7	261.5	261.5	255.1	225.9	196.8	167.6	252.9	22.9	252.9	252.9	243.9	215.2	186.4	157.7
8000	77	342.8	22.5	163.9	133.7	103.5	-	-	-	327.0	24.8	159.4	129.4	99.4	-	-	-
	72	324.7	21.7	215.3	185.1	154.9	124.7	-	-	308.2	24.1	209.1	179.2	149.2	119.3	-	-
	67	306.6	20.9	266.7	236.5	206.3	176.2	146.0	-	289.4	23.3	258.9	229.0	199.0	169.1	139.1	-
	62	272.2	20.6	272.2	272.2	247.1	216.9	186.7	156.5	261.8	23.0	261.8	261.8	240.8	210.8	180.9	150.9
	57	271.2	20.6	271.2	271.2	265.2	235.0	204.8	174.7	260.8	23.0	260.8	260.8	253.6	223.7	193.7	163.8
8500	77	355.1	22.4	169.8	138.6	107.5	-	-	-	336.8	24.8	165.5	134.4	103.2	-	-	-
	72	336.3	21.6	223.2	192.0	160.8	129.6	-	-	317.5	24.1	217.2	186.1	154.9	123.8	-	-
	67	317.5	20.8	276.6	245.4	214.2	183.0	151.8	-	298.2	23.4	268.9	237.8	206.6	175.5	144.3	-
	62	282.0	20.5	282.0	282.0	256.5	225.3	194.1	162.9	269.7	23.0	269.7	269.7	250.0	218.8	187.7	156.5
	57	280.9	20.5	280.9	280.9	275.3	244.1	212.9	181.7	268.7	23.0	268.7	268.7	263.3	232.1	201.0	169.8
10500	72	335.8	21.9	255.6	214.9	174.3	133.6	-	-	319.3	24.3	246.4	206.8	167.3	127.7	-	-
	67	317.1	21.1	296.6	272.8	232.1	191.5	150.8	-	299.8	23.6	285.2	262.6	223.1	183.6	144.0	-
	62	281.5	20.8	281.5	281.5	268.8	228.1	187.5	146.8	271.2	23.2	271.2	271.2	261.3	221.8	182.3	142.7
	57	280.5	20.8	280.5	280.5	277.6	237.0	196.4	155.7	270.2	23.2	270.2	270.2	267.5	227.9	188.4	148.9
		95°F							105°F								
7500	77	303.6	26.9	148.4	120.1	91.7	-	-	-	293.7	29.9	145.8	118.0	90.2	-	-	-
	72	284.7	26.3	194.7	166.4	138.1	109.7	-	-	272.9	29.2	191.3	163.5	135.7	107.9	-	-
	67	265.7	25.6	241.1	212.7	184.4	156.1	127.7	-	252.1	28.4	236.7	208.9	181.1	153.3	125.6	-
	62	245.3	25.2	245.3	245.3	225.5	197.2	168.9	140.5	232.9	27.8	232.9	232.9	221.3	193.5	165.7	137.9
	57	244.4	25.2	244.4	244.4	232.8	204.4	176.1	147.7	232.1	27.8	232.1	232.1	224.6	196.8	169.1	141.3
8000	77	311.1	27.1	154.8	125.1	95.4	-	-	-	299.2	30.0	151.9	122.2	92.9	-	-	-
	72	291.7	26.4	203.0	173.3	143.5	113.8	-	-	278.0	29.3	198.3	169.0	139.7	110.4	-	-
	67	272.2	25.8	251.2	221.4	191.7	162.0	132.3	-	256.7	28.5	244.7	215.8	186.5	157.2	128.0	-
	62	251.3	25.3	251.3	251.3	234.5	204.8	175.0	145.3	237.2	27.9	237.2	237.2	227.9	198.6	169.3	140.0
	57	250.4	25.3	250.4	250.4	242.0	212.3	182.6	152.8	236.4	27.9	236.4	236.4	231.4	202.1	172.8	143.5
8500	77	318.6	27.2	161.2	130.1	99.0	-	-	-	304.6	30.1	158.0	126.4	95.6	-	-	-
	72	298.7	26.6	211.3	180.1	149.0	117.9	-	-	283.0	29.4	205.3	174.5	143.8	113.0	-	-
	67	278.8	25.9	261.3	230.2	199.0	167.9	136.8	-	261.4	28.6	252.7	222.7	191.9	161.1	130.3	-
	62	257.4	25.5	257.4	257.4	243.5	212.3	181.2	150.1	241.5	28.0	241.5	241.5	234.4	203.7	172.9	142.1
	57	256.4	25.5	256.4	256.4	251.3	220.2	189.0	157.9	240.7	28.0	240.7	240.7	238.1	207.3	176.5	145.7
10500	72	302.7	26.7	237.1	198.7	160.3	121.9	-	-	288.7	29.5	231.0	193.9	156.7	119.5	-	-
	67	282.6	26.0	273.8	252.5	214.1	175.6	137.2	-	266.7	28.8	262.3	244.4	209.2	172.0	134.8	-
	62	260.9	25.6	260.9	260.9	253.9	215.5	177.1	138.6	246.4	28.1	246.4	246.4	242.8	205.7	168.5	131.3
	57	259.9	25.6	259.9	259.9	257.3	218.9	180.5	142.0	245.6	28.1	245.6	245.6	244.3	207.1	169.9	132.7
		115°F							125°F								
7500	77	283.9	32.9	143.2	116.0	88.8	-	-	-	274.0	36.0	143.8	113.9	87.3	-	-	-
	72	261.2	32.1	187.8	160.6	133.3	106.1	-	-	249.4	35.0	184.3	157.6	130.9	104.3	-	-
	67	238.4	31.2	232.4	205.1	177.9	150.6	123.4	-	224.8	34.0	224.8	201.3	174.6	147.9	121.2	-
	62	220.4	30.5	220.4	220.4	217.0	189.8	162.6	135.3	208.0	33.1	208.0	208.0	208.0	186.1	159.4	132.7
	57	219.9	30.5	219.9	219.9	216.5	189.3	162.0	134.8	207.7	33.1	207.7	207.7	207.7	181.7	155.0	128.3
8000	77	287.2	33.0	149.0	119.3	90.5	-	-	-	275.3	35.9	152.0	116.4	88.0	-	-	-
	72	264.2	32.1	193.6	164.7	135.9	107.1	-	-	250.5	35.0	188.9	160.5	132.1	103.7	-	-
	67	241.3	31.3	238.2	210.2	181.3	152.5	123.6	-	225.8	34.0	225.8	204.5	176.1	147.7	119.3	-
	62	223.0	30.5	223.0	223.0	221.2	192.4	163.5	134.7	208.9	33.1	208.9	208.9	208.9	186.2	157.8	129.4
	57	222.5	30.5	222.5	222.5	220.7	191.9	163.0	134.2	208.6	33.1	208.6	208.6	208.6	181.6	153.2	124.8
8500	77	290.6	33.0	154.7	122.6	92.2	-	-	-	276.6	35.9	160.2	118.9	88.8	-	-	-
	72	267.3	32.1	199.4	168.9	138.5	108.0	-	-	251.7	34.9	193.4	163.3	133.2	103.1	-	-
	67	244.1	31.3	244.1	215.2	184.8	154.3	123.9	-	226.7	34.0	226.7	207.7	177.6	147.5	117.4	-
	62	225.7	30.5	225.7	225.7	225.4	195.0	164.5	134.1	209.8	33.0	209.8	209.8	209.8	186.3	156.2	126.0
	57	225.1	30.5	225.1	225.1	224.9	194.4	164.0	133.5	209.5	33.0	209.5	209.5	209.5	181.6	151.5	121.3
10500	72	274.7	32.4	224.9	189.0	153.1	117.2	-	-	260.6	35.2	218.8	184.2	149.5	114.8	-	-
	67	250.8	31.5	250.8	236.3	204.3	168.4	132.4	-	234.9	34.3	234.9	228.3	199.4	164.7	130.0	-
	62	231.9	30.7	231.9	231.9	231.7	195.8	159.9	124.0	217.3	33.3	217.3	217.3	217.3	186.0	151.3	116.7
	57	231.3	30.7	231.3	231.3	231.2	195.3	159.4	123.4	217.0	33.3	217.0	217.0	217.0	183.5	148.8	114.1

- The capacities are gross ratings. For net capacity, deduct air blower motor, MBh = 3.415 x kW. Refer to the appropriate Blower Performance table for the kW of the supply air blower motor.
- These ratings include the condensate fan motors and the compressor motors but not the supply air blower motor.

TABLE 5: DC300 COOLING CAPACITIES - 25 TON (METRIC)

Air on Evaporator Coil		Temperature of Air on Condenser Coil															
m ³ /s	WB (°C)	Total Cap. ¹ (kW)	Total Input ² (kW)	Sensible Capacity (kW) Return Dry Bulb (°C)						Total Cap. ¹ (kW)	Total Input ² (kW)	Sensible Capacity (kW) Return Dry Bulb (°C)					
				32	29	27	24	22	18			32	29	27	24	22	18
		24°C							29°C								
3.5	25	96.9	22.6	46.3	37.8	29.2	-	-	-	93.0	24.7	44.9	36.5	28.1	-	-	-
	22	91.8	21.8	60.8	52.3	43.7	35.2	-	-	87.7	24.0	59.0	50.5	42.1	33.7	-	-
	19	86.7	20.9	75.3	66.8	58.2	49.7	41.1	-	82.3	23.3	73.0	64.6	56.1	47.7	39.3	-
	17	77.0	20.7	77.0	77.0	69.7	61.1	52.6	44.0	74.4	22.9	74.4	74.4	67.9	59.5	51.1	42.6
3.8	14	76.7	20.7	76.7	76.7	74.8	66.3	57.7	49.1	74.2	22.9	74.2	74.2	71.5	63.1	54.7	46.2
	25	100.5	22.5	48.1	39.2	30.4	-	-	-	95.9	24.8	46.7	37.9	29.2	-	-	-
	22	95.2	21.7	63.1	54.3	45.4	36.6	-	-	90.4	24.1	61.3	52.5	43.8	35.0	-	-
	19	89.9	20.9	78.2	69.4	60.5	51.7	42.8	-	84.9	23.3	75.9	67.2	58.4	49.6	40.8	-
4.0	17	79.8	20.6	79.8	79.8	72.5	63.6	54.8	45.9	76.8	23.0	76.8	76.8	70.6	61.8	53.0	44.3
	14	79.5	20.6	79.5	79.5	77.8	68.9	60.1	51.2	76.5	23.0	76.5	76.5	74.4	65.6	56.8	48.0
	25	104.1	22.4	49.8	40.7	31.5	-	-	-	98.8	24.8	48.5	39.4	30.3	-	-	-
	22	98.6	21.6	65.5	56.3	47.2	38.0	-	-	93.1	24.1	63.7	54.6	45.4	36.3	-	-
5.0	19	93.1	20.8	81.1	72.0	62.8	53.7	44.5	-	87.4	23.4	78.9	69.7	60.6	51.5	42.3	-
	17	82.7	20.5	82.7	82.7	75.2	66.1	56.9	47.8	79.1	23.0	79.1	79.1	73.3	64.2	55.0	45.9
	14	82.4	20.5	82.4	82.4	80.7	71.6	62.4	53.3	78.8	23.0	78.8	78.8	77.2	68.1	58.9	49.8
	22	98.5	21.9	74.9	63.0	51.1	39.2	-	-	93.6	24.3	72.2	60.7	49.1	37.5	-	-
5.0	19	93.0	21.1	87.0	80.0	68.1	56.2	44.2	-	87.9	23.6	83.6	77.0	65.4	53.8	42.2	-
	17	82.5	20.8	82.5	82.5	78.8	66.9	55.0	43.1	79.5	23.2	79.5	79.5	76.6	65.0	53.4	41.9
	14	82.2	20.8	82.2	82.2	81.4	69.5	57.6	45.7	79.2	23.2	79.2	79.2	78.4	66.8	55.3	43.7
			35°C							41°C							
3.5	25	89.0	26.9	43.5	35.2	26.9	-	-	-	86.1	29.9	42.8	34.6	26.5	-	-	-
	22	83.5	26.3	57.1	48.8	40.5	32.2	-	-	80.0	29.2	56.1	47.9	39.8	31.6	-	-
	19	77.9	25.6	70.7	62.4	54.1	45.8	37.5	-	73.9	28.4	69.4	61.3	53.1	45.0	36.8	-
	17	71.9	25.2	71.9	71.9	66.1	57.8	49.5	41.2	68.3	27.8	68.3	68.3	64.9	56.7	48.6	40.4
3.8	14	71.7	25.2	71.7	71.7	68.3	59.9	51.6	43.3	68.1	27.8	68.1	68.1	65.9	57.7	49.6	41.4
	25	91.2	27.1	45.4	36.7	28.0	-	-	-	87.7	30.0	44.5	35.8	27.3	-	-	-
	22	85.5	26.4	59.5	50.8	42.1	33.4	-	-	81.5	29.3	58.2	49.6	41.0	32.4	-	-
	19	79.8	25.8	73.7	64.9	56.2	47.5	38.8	-	75.3	28.5	71.8	63.3	54.7	46.1	37.5	-
4.0	17	73.7	25.3	73.7	73.7	68.8	60.1	51.3	42.6	69.6	27.9	69.6	69.6	66.8	58.2	49.6	41.1
	14	73.4	25.3	73.4	73.4	71.0	62.3	53.5	44.8	69.3	27.9	69.3	69.3	67.8	59.3	50.7	42.1
	25	93.4	27.2	47.3	38.2	29.0	-	-	-	89.3	30.1	46.3	37.1	28.0	-	-	-
	22	87.6	26.6	62.0	52.8	43.7	34.6	-	-	83.0	29.4	60.2	51.2	42.2	33.1	-	-
5.0	19	81.8	25.9	76.6	67.5	58.4	49.2	40.1	-	76.7	28.6	74.1	65.3	56.3	47.3	38.2	-
	17	75.5	25.5	75.5	75.5	71.4	62.3	53.1	44.0	70.8	28.0	70.8	70.8	68.8	59.7	50.7	41.7
	14	75.2	25.5	75.2	75.2	73.7	64.6	55.4	46.3	70.6	28.0	70.6	70.6	69.8	60.8	51.8	42.7
	22	88.8	26.7	69.5	58.3	47.0	35.7	-	-	84.7	29.5	67.8	56.9	46.0	35.0	-	-
5.0	19	82.9	26.0	80.3	74.0	62.8	51.5	40.2	-	78.2	28.8	76.9	71.7	61.3	50.4	39.5	-
	17	76.5	25.6	76.5	76.5	74.5	63.2	51.9	40.7	72.2	28.1	72.2	72.2	71.2	60.3	49.4	38.5
	14	76.2	25.6	76.2	76.2	75.5	64.2	52.9	41.7	72.0	28.1	72.0	72.0	71.6	60.7	49.8	38.9
			46°C							52°C							
3.5	25	83.2	32.9	42.0	34.0	26.0	-	-	-	80.4	36.0	42.2	33.4	25.6	-	-	-
	22	76.6	32.1	55.1	47.1	39.1	31.1	-	-	73.1	35.0	54.1	46.2	38.4	30.6	-	-
	19	69.9	31.2	68.1	60.2	52.2	44.2	36.2	-	65.9	34.0	65.9	59.0	51.2	43.4	35.6	-
	17	64.6	30.5	64.6	64.6	63.6	55.7	47.7	39.7	61.0	33.1	61.0	61.0	61.0	54.6	46.7	38.9
3.8	14	64.5	30.5	64.5	64.5	63.5	55.5	47.5	39.5	60.9	33.1	60.9	60.9	60.9	53.3	45.5	37.6
	25	84.2	33.0	43.7	35.0	26.5	-	-	-	80.7	35.9	44.6	34.1	25.8	-	-	-
	22	77.5	32.1	56.8	48.3	39.9	31.4	-	-	73.5	35.0	55.4	47.1	38.7	30.4	-	-
	19	70.8	31.3	69.9	61.6	53.2	44.7	36.3	-	66.2	34.0	66.2	60.0	51.6	43.3	35.0	-
4.0	17	65.4	30.5	65.4	65.4	64.9	56.4	48.0	39.5	61.3	33.1	61.3	61.3	61.3	54.6	46.3	37.9
	14	65.3	30.5	65.3	65.3	64.7	56.3	47.8	39.3	61.2	33.1	61.2	61.2	61.2	53.3	44.9	36.6
	25	85.2	33.0	45.4	36.0	27.0	-	-	-	81.1	35.9	47.0	34.9	26.0	-	-	-
	22	78.4	32.1	58.5	49.5	40.6	31.7	-	-	73.8	34.9	56.7	47.9	39.1	30.2	-	-
5.0	19	71.6	31.3	71.6	63.1	54.2	45.3	36.3	-	66.5	34.0	66.5	60.9	52.1	43.3	34.4	-
	17	66.2	30.5	66.2	66.2	66.1	57.2	48.2	39.3	61.5	33.0	61.5	61.5	54.6	45.8	37.0	
	14	66.0	30.5	66.0	66.0	65.9	57.0	48.1	39.2	61.4	33.0	61.4	61.4	61.4	53.2	44.4	35.6
	22	80.5	32.4	66.0	55.4	44.9	34.4	-	-	76.4	35.2	64.2	54.0	43.8	33.7	-	-
5.0	19	73.5	31.5	73.5	69.3	59.9	49.4	38.8	-	68.9	34.3	68.9	66.9	58.5	48.3	38.1	-
	17	68.0	30.7	68.0	68.0	68.0	57.4	46.9	36.4	63.7	33.3	63.7	63.7	63.7	54.5	44.4	34.2
	14	67.8	30.7	67.8	67.8	67.8	57.3	46.7	36.2	63.6	33.3	63.6	63.6	63.6	53.8	43.6	33.5

1. The capacities are gross ratings. For net capacity, deduct air blower motor, MBh = 3.415 x kW. Refer to the appropriate Blower Performance table for the kW of the supply air blower motor.

2. These ratings include the condensate fan motors and the compressor motors but not the supply air blower motor.

CFM, STATIC PRESSURE, AND POWER - ALTI-TUDE AND TEMPERATURE CORRECTIONS

The information below should be used to assist in application of product when being applied at altitudes at or exceeding 1000 feet above sea level.

The air flow rates listed in the standard blower performance tables are based on standard air at sea level. As the altitude or temperature increases, the density of air decreases. In

order to use the indoor blower tables for high altitude applications, certain corrections are necessary.

A centrifugal fan is a "constant volume" device. This means that, if the rpm remains constant, the CFM delivered is the same regardless of the density of the air. However, since the air at high altitude is less dense, less static pressure will be generated and less power will be required than a similar application at sea level. Air density correction factors are shown in Table 7 and Figure 1.

TABLE 6: ALTITUDE CORRECTION FACTORS (°C/METER)

AIR TEMP °C	ALTITUDE (METER)										
	0	305	610	914	1219	1524	1829	2134	2438	2743	3048
4.4	1.060	1.022	0.986	0.950	0.916	0.882	0.849	0.818	0.788	0.758	0.729
10	1.039	1.002	0.966	0.931	0.898	0.864	0.832	0.802	0.772	0.743	0.715
15.5	1.019	0.982	0.948	0.913	0.880	0.848	0.816	0.787	0.757	0.729	0.701
21	1.000	0.964	0.930	0.896	0.864	0.832	0.801	0.772	0.743	0.715	0.688
26.6	0.982	0.947	0.913	0.880	0.848	0.817	0.787	0.758	0.730	0.702	0.676
32	0.964	0.929	0.897	0.864	0.833	0.802	0.772	0.744	0.716	0.689	0.663
38	0.946	0.912	0.880	0.848	0.817	0.787	0.758	0.730	0.703	0.676	0.651

TABLE 7: ALTITUDE CORRECTION FACTORS (°F/FEET)

AIR TEMP °F	ALTITUDE (FEET)										
	0	1000	2000	3000	4000	5000	6000	7000	8000	9000	10000
40	1.060	1.022	0.986	0.950	0.916	0.882	0.849	0.818	0.788	0.758	0.729
50	1.039	1.002	0.966	0.931	0.898	0.864	0.832	0.802	0.772	0.743	0.715
60	1.019	0.982	0.948	0.913	0.880	0.848	0.816	0.787	0.757	0.729	0.701
70	1.000	0.964	0.930	0.896	0.864	0.832	0.801	0.772	0.743	0.715	0.688
80	0.982	0.947	0.913	0.880	0.848	0.817	0.787	0.758	0.730	0.702	0.676
90	0.964	0.929	0.897	0.864	0.833	0.802	0.772	0.744	0.716	0.689	0.663
100	0.946	0.912	0.880	0.848	0.817	0.787	0.758	0.730	0.703	0.676	0.651

The examples below will assist in determining the airflow performance of the product at altitude.

Example 1: What are the corrected CFM, static pressure, and BHP at an elevation of 5,000 ft. if the blower performance data is 6,000 CFM, 1.5 IWC and 4.0 BHP?

Solution: At an elevation of 5,000 ft the indoor blower will still deliver 6,000 CFM if the rpm is unchanged. However, Table 7 must be used to determine the static pressure and BHP. Since no temperature data is given, we will assume an air temperature of 70°F. Table 7 shows the correction factor to be 0.832.

$$\text{Corrected static pressure} = 1.5 \times 0.832 = 1.248 \text{ IWC}$$

$$\text{Corrected BHP} = 4.0 \times 0.832 = 3.328$$

Example 2: A system, located at 5,000 feet of elevation, is to deliver 6,000 CFM at a static pressure of 1.5". Use the unit blower tables to select the blower speed and the BHP requirement.

Solution: As in the example above, no temperature information is given so 70°F is assumed.

The 1.5" static pressure given is at an elevation of 5,000 ft. The first step is to convert this static pressure to equivalent sea level conditions.

$$\text{Sea level static pressure} = 1.5 / .832 = 1.80"$$

Enter the blower table at 6000 sCFM and static pressure of 1.8". The rpm listed will be the same rpm needed at 5,000 ft.

Suppose that the corresponding BHP listed in the table is 3.2. This value must be corrected for elevation.

$$\text{BHP at 5,000 ft} = 3.2 \times .832 = 2.66$$

Altitude/Temperature Conversion Factor

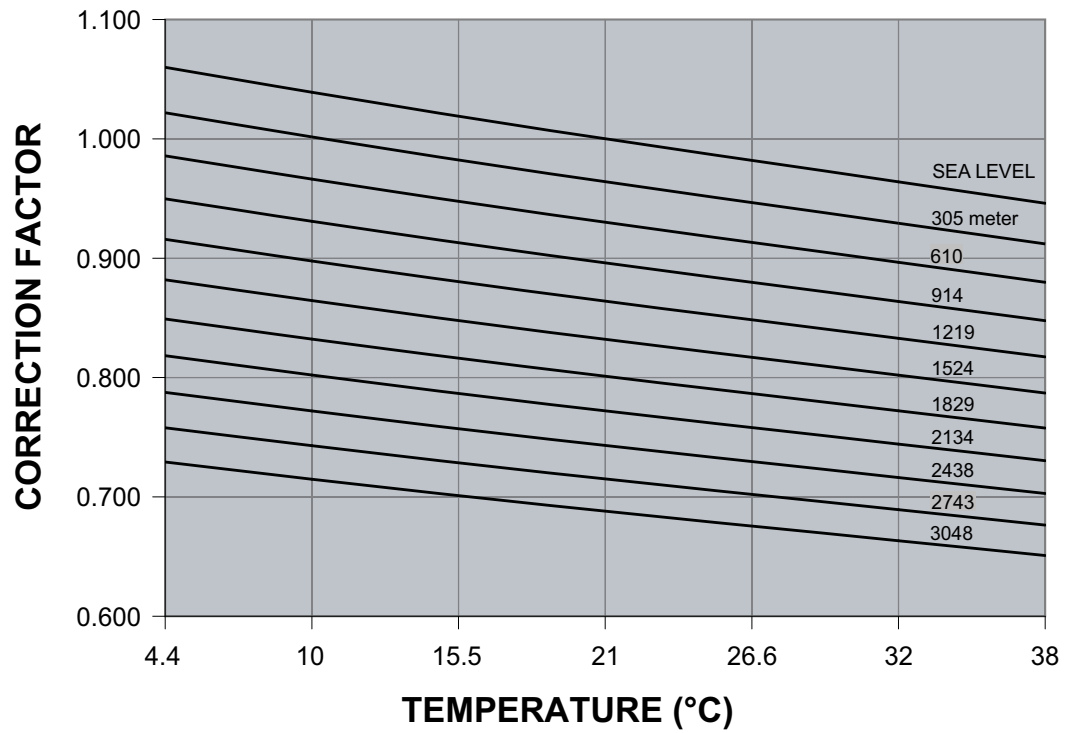

FIGURE 1 - ALTITUDE/TEMPERATURE CONVERSION FACTOR (°C/METER)

Altitude/Temperature Conversion Factor

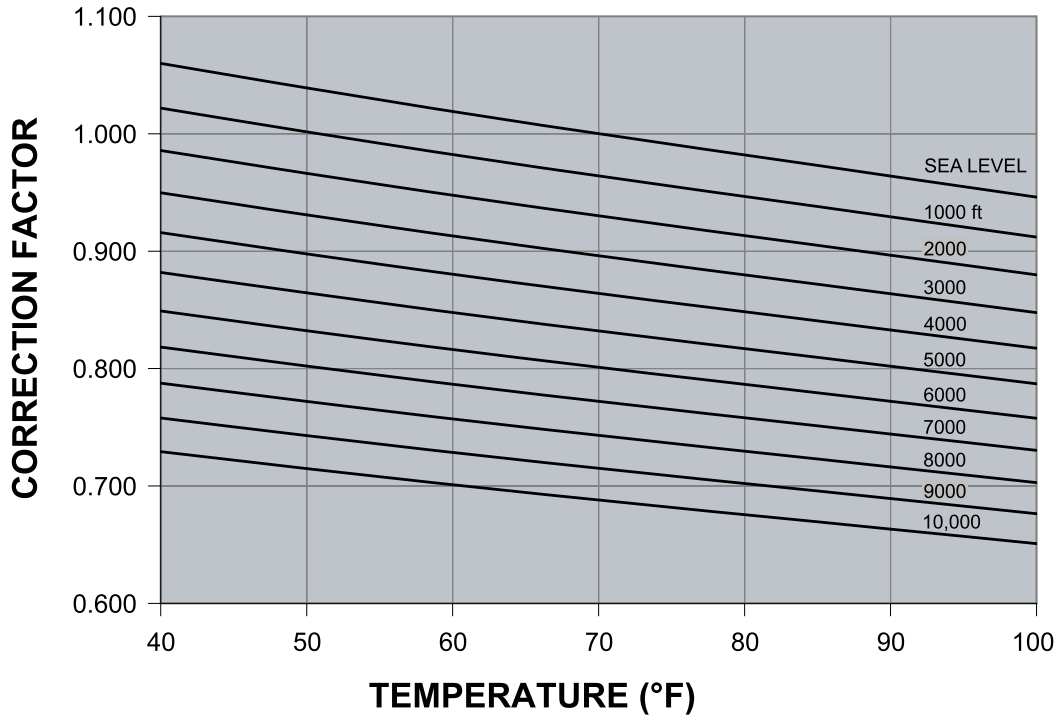

FIGURE 2 - ALTITUDE/TEMPERATURE CONVERSION FACTOR (°F/FEET)

TABLE 8: BLOWER PERFORMANCE - DC300 - BOTTOM DUCT CONNECTIONS (COOLING APPLICATIONS)

DC300 UNIT - DOWNFLOW DUCT CONNECTIONS										
BLOWER SPEED (rpm)	PULLEY TURNS OPEN	7500 CFM			8750 cfm			10000 cfm		
		ESP (iwg)	OUTPUT (bhp)	INPUT (kW)	ESP (iwg)	OUTPUT (bhp)	INPUT (kW)	ESP (iwg)	OUTPUT (bhp)	INPUT (kW)
945	6.0	1.2	5.6	4.6	0.8	7.0	5.7	0.3	8.4	6.9
975	5.0	1.4	5.9	4.9	1.0	7.3	6.0	0.5	8.8	7.2
1005	4.0	1.6	6.2	5.1	1.2	7.7	6.3	0.7	9.2	7.6
1040	3.0	1.8	6.6	5.4	1.4	8.1	6.7	0.9	9.7	8.0
1070	2.0	2.0	6.9	5.7	1.6	8.5	7.0	1.1	10.2	8.3
1100	1.0	2.1	7.3	6.0	1.8	8.9	7.3	1.3	10.6	8.7
1130	0.0	2.3	7.6	6.2	2.0	9.3	7.6	1.5	11.0	9.0

DC300 UNIT - DOWNFLOW DUCT CONNECTIONS										
BLOWER SPEED (rpm)	PULLEY TURNS OPEN	3.53 m ³ /Sec.			4.13 m ³ /Sec.			4.72 m ³ /Sec.		
		ESP (Pa)	OUTPUT (bhp)	INPUT (kW)	ESP (Pa)	OUTPUT (bhp)	INPUT (kW)	ESP (Pa)	OUTPUT (bhp)	INPUT (kW)
945	6.0	303	5.6	4.6	198	7.0	5.7	71	8.4	6.9
975	5.0	347	5.9	4.9	244	7.3	6.0	120	8.8	7.2
1005	4.0	391	6.2	5.1	291	7.7	6.3	169	9.2	7.6
1040	3.0	443	6.6	5.4	347	8.1	6.7	228	9.7	8.0
1070	2.0	489	6.9	5.7	396	8.5	7.0	280	10.2	8.3
1100	1.0	536	7.3	6.0	445	8.9	7.3	332	10.6	8.7
1130	0.0	583	7.6	6.2	495	9.3	7.6	385	11.0	9.0

DC300 UNIT - DOWNFLOW DUCT CONNECTIONS - GAS HEAT MODELS										
BLOWER SPEED (rpm)	PULLEY TURNS OPEN	7500 CFM			8750 cfm			10000 cfm		
		ESP (iwg)	OUTPUT (bhp)	INPUT (kW)	ESP (iwg)	OUTPUT (bhp)	INPUT (kW)	ESP (iwg)	OUTPUT (bhp)	INPUT (kW)
945	6.0	1.0	5.6	4.6	0.3	7.0	5.7	-	-	-
975	5.0	1.2	5.9	4.9	0.5	7.3	6.0	-	-	-
1005	4.0	1.4	6.2	5.1	0.7	7.7	6.3	-	-	-
1040	3.0	1.6	6.6	5.4	0.9	8.1	6.7	0.2	9.7	8.0
1070	2.0	1.8	6.9	5.7	1.1	8.5	7.0	0.4	10.2	8.3
1100	1.0	2.0	7.3	6.0	1.3	8.9	7.3	0.6	10.6	8.7
1130	0.0	2.2	7.6	6.2	1.5	9.3	7.6	0.8	11.0	9.0

DC300 UNIT - DOWNFLOW DUCT CONNECTIONS - GAS HEAT MODELS										
BLOWER SPEED (rpm)	PULLEY TURNS OPEN	3.53 m ³ /sec.			4.13 m ³ /sec.			4.72 m ³ /sec.		
		ESP (Pa)	OUTPUT (bhp)	INPUT (kW)	ESP (Pa)	OUTPUT (bhp)	INPUT (kW)	ESP (Pa)	OUTPUT (bhp)	INPUT (kW)
945	6.0	258	5.6	4.6	87	7.0	5.7	-	-	-
975	5.0	301	5.9	4.9	133	7.3	6.0	-	-	-
1005	4.0	345	6.2	5.1	180	7.7	6.3	-	-	-
1040	3.0	398	6.6	5.4	236	8.1	6.7	43	9.7	8.0
1070	2.0	444	6.9	5.7	285	8.5	7.0	94	10.2	8.3
1100	1.0	490	7.3	6.0	334	8.9	7.3	146	10.6	8.7
1130	0.0	537	7.6	6.2	384	9.3	7.6	199	11.0	9.0

TABLE 9: STATIC RESISTANCES¹ - EXTERNAL STATIC PRESSURE DROP

DESCRIPTION		RESISTANCE, Pa / iwg		
		m ³ /s / CFM		
		3.78 / 8,000	4.25 / 9,000	4.72 / 10,000
WET COIL		25 / 0.1	25 / 0.1	25 / 0.1
GAS HEAT		25 / 0.1	25 / 0.1	25 / 0.1
ELECTRIC HEAT OPTIONS	18 KW	25 / 0.1	25 / 0.1	25 / 0.1
	36 KW	25 / 0.1	50 / 0.2	75 / 0.3
	54 KW	50 / 0.2	75 / 0.3	100 / 0.4
	72 KW	50 / 0.2	100 / 0.4	150 / 0.6
ECONOMIZER OPTION		25 / 0.1	25 / 0.1	25 / 0.1
HORIZONTAL DUCT CONNECTIONS		50 / 0.2	75 / 0.3	125 / 0.5

1. Deduct these resistance values from the available unit ESP values listed in the respective blower performance table except for Horizontal Duct Connections
Add these values due to less airflow resistance.

TABLE 10: BLOWER MOTOR AND DRIVE DATA

MODEL SIZE	BLOWER RANGE (RPM)	MOTOR ¹			ADJUSTABLE MOTOR PULLEY ²			FIXED BLOWER PULLEY			(NOTCHED)		
		kW / HP	FRAME	EFF. (%)	DESIG-NATION DIA. mm (IN.)	PITCH	BORE	DESIG-NATION	PITCH DIA.	BORE	DESIG-NATION	PITCH LENGT H	QTY
300	950 / 1130	7.5 / 10	254T	89	1LVP58 B70A	157-188 6.2-7.4	A2 BUSHING	1B5V94	241 (9.5)	B BUSHING	5VX840	2134 (84)	1

- All motors have a nominal speed of 1450 RPM, a 1.15 service factor and a solid base. They can operate to the limit of their service factor because they are located in the moving air, upstream of any heating service.
- Do NOT close this pulley below one turn.

TABLE 11: PHYSICAL DATA

MODELS		DC300		
EVAPORATOR BLOWER	CENTRIFUGAL BLOWER (Dia. x Wd.) in.		18x15	
	(Dia. x Wd.) mm.		457x381	
	FAN MOTOR HP/kW		10/7.5	
EVAPORATOR COIL	ROWS DEEP		4	
	FINS PER In./25mm		13.5	
	FACE AREA Ft. ² /m ²		25/2.3	
CONDENSER FAN (Two Per Unit)	PROPELLER DIA. In./mm (Each)		30/762	
	FAN MOTOR HP/kW (Each)		1/0.7	
	NOM. AIRFLOW TOTAL CFM (Each)		7,200	
	m ³ /s (Each)		3.4	
CONDENSER COIL	ROWS DEEP		3	
	FINS PER In./25mm		15	
	FACE AREA Ft. ² /m ²		43.3/4.02	
COMPRESSOR (Qty. Per Unit)	5 TON HERMETIC (RECIP.)		~	
	10 TON TANDEM (RECIP.)		~	
	10 TON SCROLL		~	
	12.5 TON		2	
FILTERS	QUANTITY PER UNIT (12 X 24 X 2 or 4) In.		12	
	(304 X 609 X 51 or 102) mm.			
	TOTAL FACE AREA Ft. ² /m ²		24/2.2	
CHARGE	REFRIGENT 407C Lb./kg.	SYSTEM No.1	25.5/11.6	
		SYSTEM No. 2	24.5/11.1	
OPERATING WEIGHTS Lb. / kg	BASIC UNIT	COOLING ONLY		2709/1229
		GAS / ELECTRIC	N24	2909/1319
			N32	2971/1347
	OPTIONS	ECONOMIZER		160/73
		ECONOMIZER WITH POWER EXHAUST		245/111
		MOTORIZED DAMPER		150/68
		ELECTRIC HEATER	18 KW	25/11
			36 KW	30/14
			54 KW	35/16
	72 KW		40/18	
	ACCESSORIES	ROOF CURB		185/84
		BAROMETRIC DAMPER		45/20
		ECONOMIZER / MOTORIZED DAMPER RAIN HOOD		55/25
		ECONOMIZER / POWER EXHAUST RAIN HOOD		90/41
		WOOD SKID*		220/100

*Note: Allows handling of unit using 90"/2300mm long forks.

R-407 units may require a super heat and sub-cooling check at the job site to ensure proper charge and operation.

**TABLE 12: ELECTRICAL DATA - COOLING ONLY
UNITS AND UNITS WITH GAS HEAT**

MODEL	POWER SUPPLY	COMPRESSORS		COND. FAN MOTORS #1 & #2		SUPPLY AIR BLOWER MOTOR		MINIMUM CIRCUIT AMPACITY (AMPS)	MAXIMUM OVER-CURRENT DEVICE ¹ (AMPS)
		RLA (Each)	LRA (Each)	HP	FLA	HP	FLA		
DC300	380/415-3-50	22.9	145	1.0	2.1	10	19.0	74.7	90

1. Dual element, time delay fuse or HACR breaker.

VOLTAGE LIMITATIONS ¹	POWER SUPPLY	VOLTAGE	
		MIN.	MAX.
	380/415-3-50	342	457

1. Rated in accordance with ARI Standard, utilization range "A".

**TABLE 13: ELECTRICAL DATA - UNITS WITH
ELECTRIC HEAT**

MODEL DC	POWER SUPPLY	HEATER OPTION				MINIMUM CIRCUIT AMPACITY (AMPS)	MAXIMUM OVERCURRENT DEVICE ² (AMPS)
		MODEL	KW ¹	STAGES	AMPS		
300	380-3-50	E018	11.3	1	17.1	76.0	90
		E036	22.6	2	34.3	76.0	90
		E054	33.8	2	51.4	87.9	90
		E072	45.1	2	68.6	109.4	110
	415-3-50	E018	13.5	1	18.7	76.0	90
		E036	26.9	2	37.4	76.0	90
		E054	40.4	2	56.2	94.0	100
		E072	53.8	2	74.9	98.6	110

¹Electric Heat CORRECTION FACTORS:

²Dual element time delay fuse or HACR breaker.

NOMINAL VOLTAGE	VOLTAGE	KW CAP. MULTIPLIER
380	380	0.627
415	415	0.75

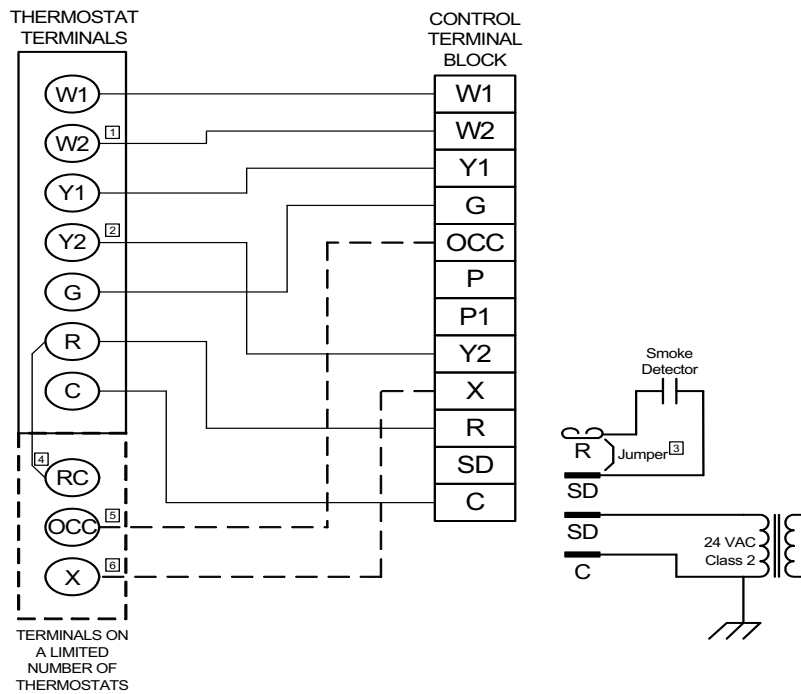

- ❑ Second stage heating not required on single stage heating units.
- ❑ Second stage cooling not required on single stage cooling units.
- ❑ Jumper is required if there is no Smoke Detector circuit.
- ❑ Jumper is required for any combination of R, RC, or RH.
- ❑ OCC is an output from the thermostat to indicate the Occupied condition.
- ❑ X is an input to the thermostat to display Error Status conditions.

FIGURE 3 - FIELD WIRING - DC ELECTRIC/ELECTRIC AND GAS/ ELECTRIC UNITS

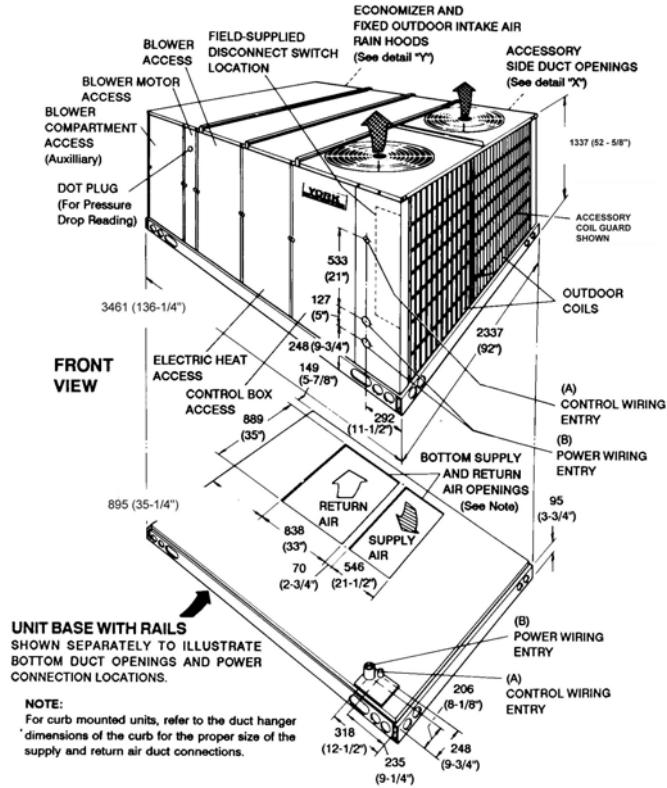

FIGURE 4 - UNIT DIMENSIONS - DC COOL & COOL/ELECTRIC HEAT

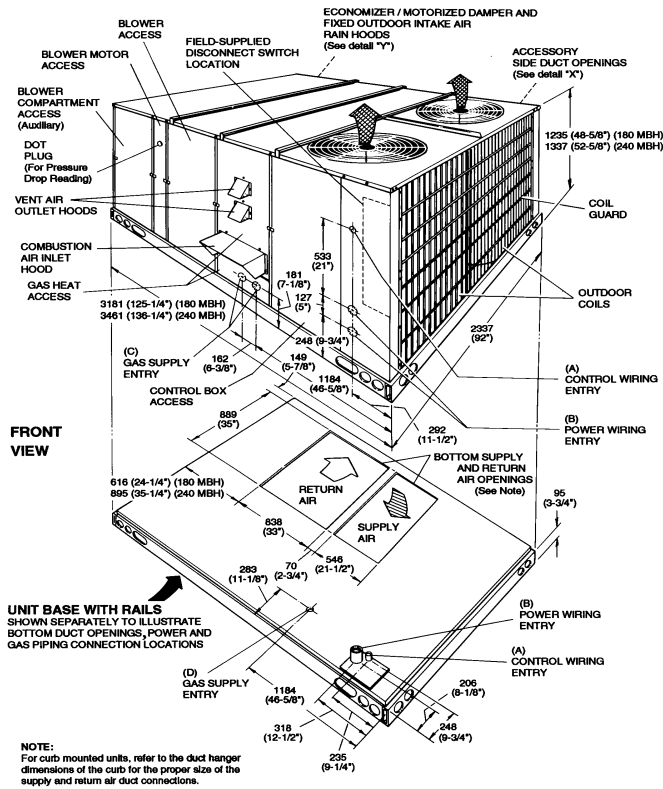

FIGURE 5 - UNIT DIMENSIONS - DC GAS HEAT

TABLE 14: UTILITIES ENTRY DATA

HOLE	OPENING SIZE (DIA.) (MM/IN.)	USED FOR	
A	29/1-1/8" KO	Control Wiring	Side
	19/3/4" NPS (Fem.)		Bottom
B	92/3-5/8" KO	Power Wiring	Side
	76/3" NPS (Fem.)		Bottom
C	60/2-3/8" KO	Gas Piping (Front) ¹	
D	43/1-11/16" Hole	Gas Piping (Bottom) ^{1, 2}	

1. One-inch gas piping NPT required.

2. Opening in the bottom of the unit can be located by the slice in the insulation.

NOTE: All entry holes should be field sealed to prevent rain water entry into the building.

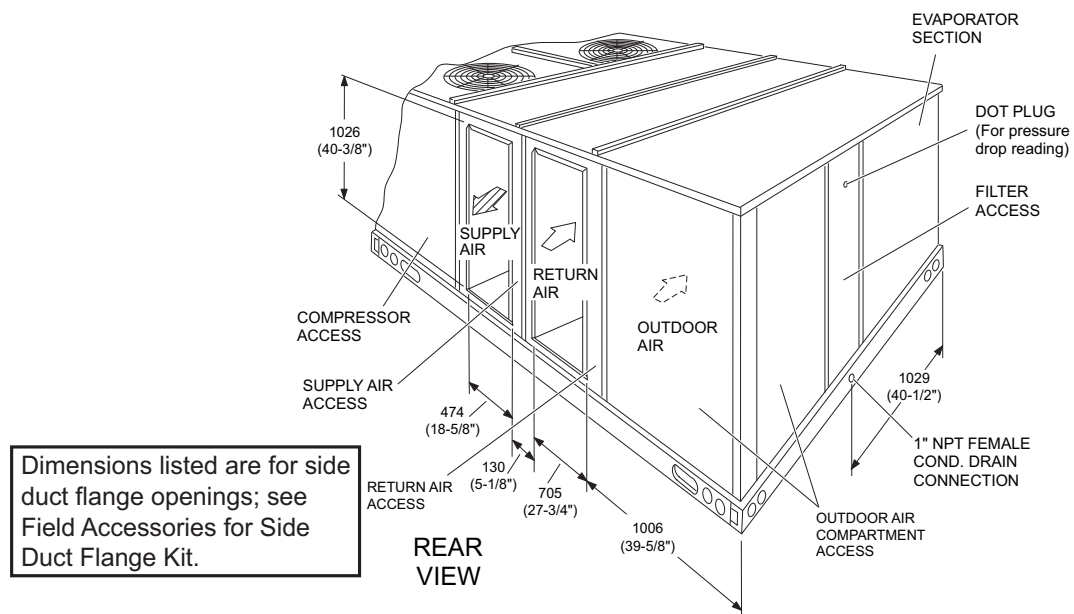
**FIGURE 6 - REAR VIEW DIMENSIONS**

NOTE: Units are shipped with the bottom duct openings covered. An accessory flange kit is available for connecting side ducts.

For bottom duct applications:

1. Remove the side panels from the supply and return air compartments to gain access to the bottom supply and return air duct covers.
2. Remove and discard the bottom duct covers. Duct openings are closed with sheet metal covers except when the unit includes a power exhaust option. The covering consists of a heavy black paper composition.
3. Replace the side supply and return air compartment panels.

For side duct applications:

1. Replace the side panels on the supply and return air compartments with the side duct flange accessory kit panels.
2. Connect ductwork to the flanges on those panels.

TABLE 15: MINIMUM CLEARANCES (MM/IN.)

LOCATION	CLEARANCE
Front	914/36"
Rear	610/24" (Less Economizer) 1245/49" (With Economizer)
Left Side (Filter Access)	610/24" (Less Economizer) 914/36" (With Economizer) ³
Right Side (Cond. Coil)	914/36"
Below Unit ¹	0/0"
Above Unit ²	1829/72" With 914/36" Maximum Horizontal Overhang (For Condenser Air Discharge)

- Units may be installed on combustible floors made from wood or class A, B, or C roof covering material.
- Units must be installed outdoors. Overhanging structures or shrubs should not obstruct condenser air discharge outlet.
- If economizer is factory installed, the unassembled rain hood must be removed from its side along position in front of evaporator coil, or in the outdoor air compartment, prior to final installation.

NOTE: ELEC / ELEC Models: Units and ductwork are approved for zero clearance to combustible material when equipped with electric heaters.

GAS / ELEC Models: A 25mm/1" clearance must be provided between any combustible material and the supply air ductwork for a distance of .9 meter/3 feet from the unit.

The products of combustion must not be allowed to accumulate within a confined space and recirculate.

Locate unit so that the vent air outlet hood is at least:

- .9 meters/3 feet above any force air inlet located within 3.0 meters/10 horizontal feet (excluding those integral to the unit).
- 1.2 meters/4 feet below, four horizontal feet from, or one foot above any door or gravity air inlet into the building.
- 1.2 meters/4 feet from electric and gas meters, regulators and relief equipment.

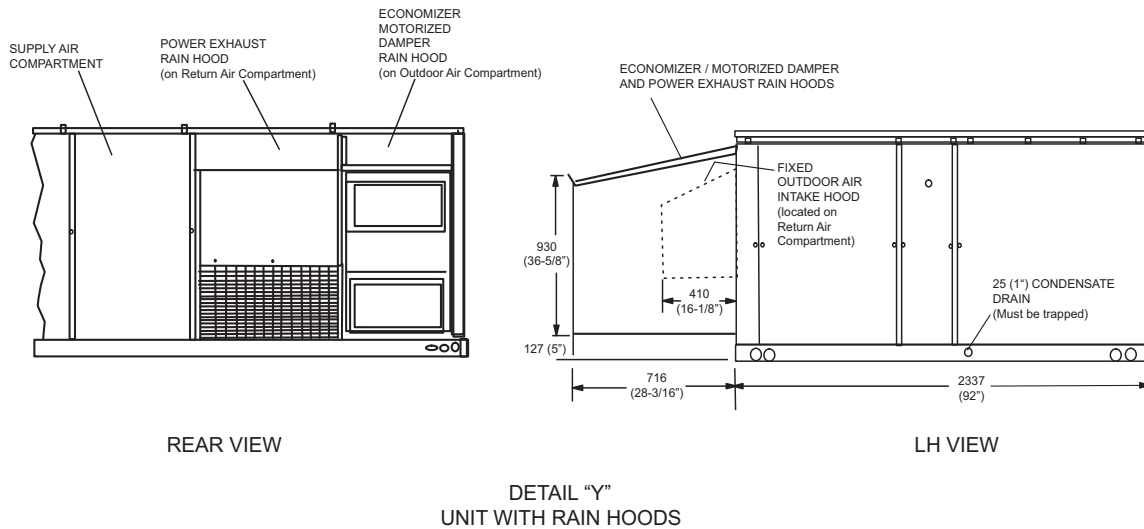

FIGURE 7 - UNIT CLEARANCES AND RAINHOOD DIMENSIONS (25 TON)

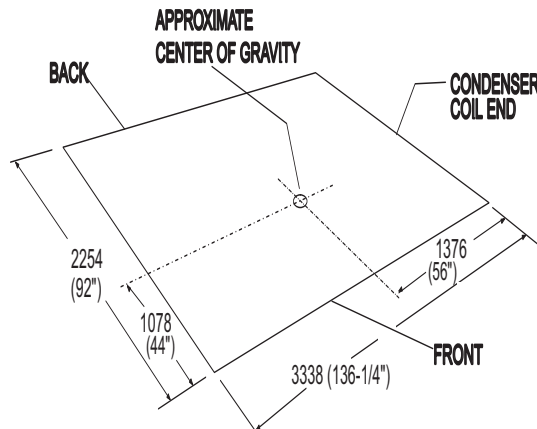

FIGURE 8 - CENTER OF GRAVITY

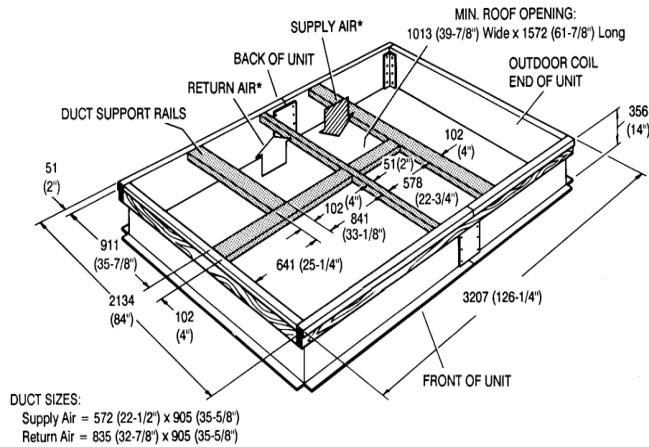
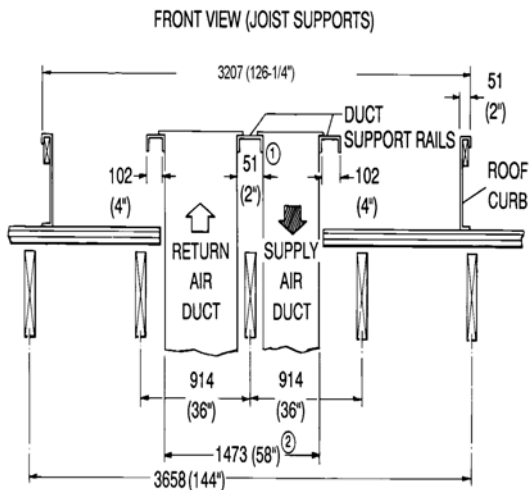

FIGURE 9 - ROOF CURB DIMENSIONS (ALL MODELS)

* Supply and Return air (including duct support rails) as shown, are typical for Downflow duct applications

For location of Sideflow duct applications (on back of unit), refer to Unit Dimension details.



- ① The 51 (2") space between the duct allows for "jumping" an existing roof joist.
- ② The 1486 (58-1/2") overall dimension of the ducts allows ductwork penetration between roof joists that are spaced on 1829 (72") centers.

NOTE: Ducts can be installed onto the curb from the roof. All electrical connections can be made inside the curb.

FIGURE 10 - ROOF CURB BENEFITS

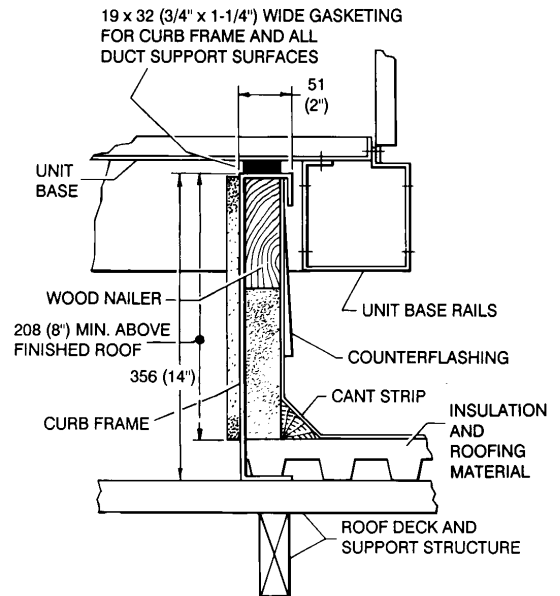

FIGURE 11 - UNIT CURB AND APPLICATIONS

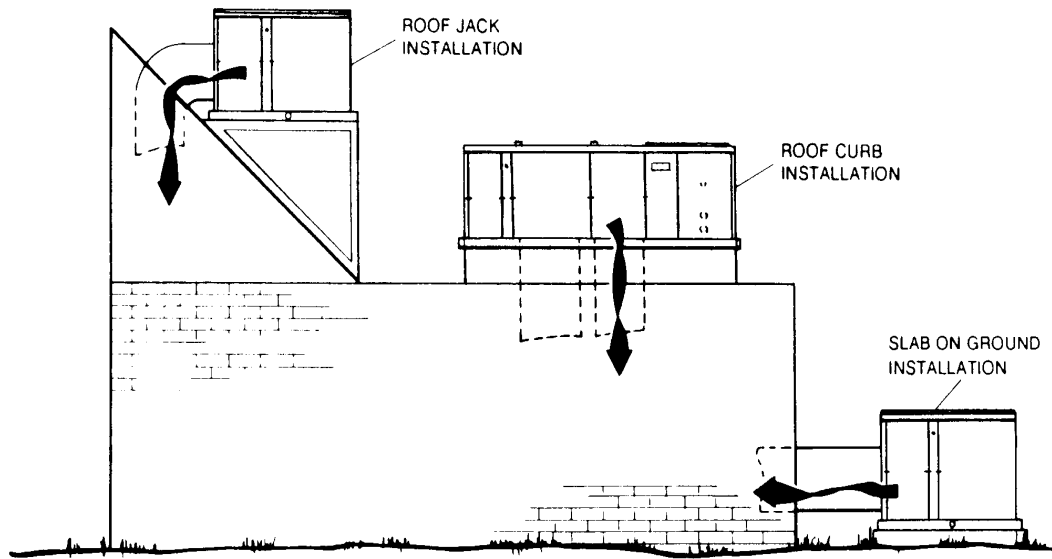

FIGURE 12 - TYPICAL APPLICATION

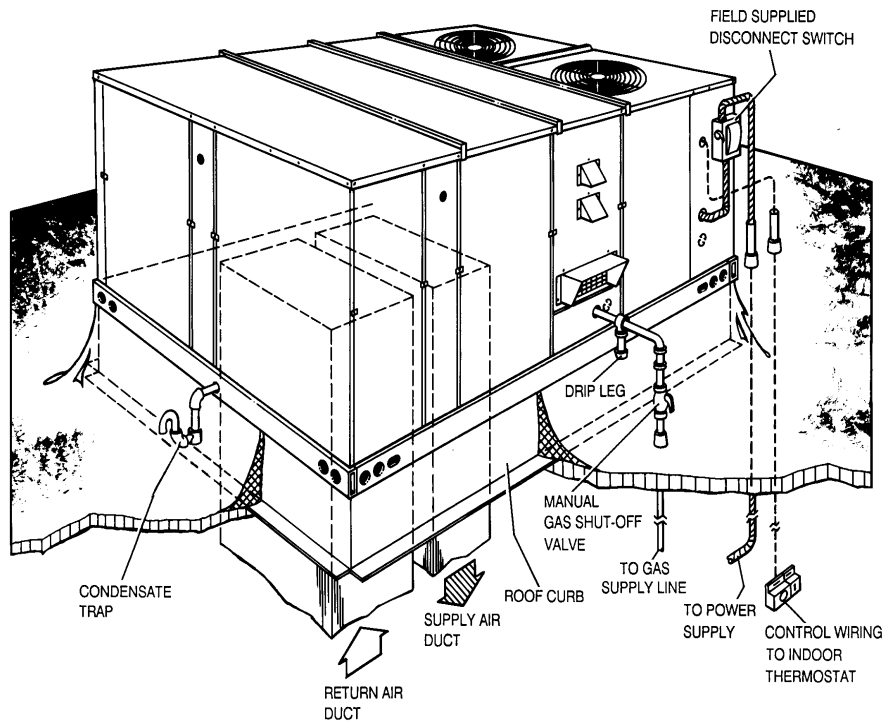

FIGURE 13 - TYPICAL ROOF-TOP INSTALLATION (GAS/ELECTRIC UNIT SHOWN)

